

Specification and scope of supply of P360.35L

Description	Specification/scope of supply
Max component length	3000mm
Max component width	1220mm
Max component thickness	350mm
Max component weight	500kg
Measuring accuracy, length & width**	+/- 35 / 75 µm*
Measuring accuracy, height** (optional)	+/- 100 µm
Measuring speed**	<0.25sec
Camera	Industrialized ultra high resolution professionally mounted in sealed enclosure
Dot Laser height measuring device (optional)	Class III R precision laser
Computer processor	Intel Quad or Dual Core
Processor speed	>3GHz
Hard disk	80Gb
Optical drive	CDRW
Screen	20 inch flatscreen or better
Printer	A4 colour inkjet printer
Peripheral equipment	Keyboard and optical mouse
Operating software	Windows 7, 64 Bit
Proprietary InspecVision software	Inspection, SPC, Reporting, Reverse engineering
Data cable	USB2 or USB3
Computer cabinet	Industrial dust-proof enclosure
Light table construction	Frame with removable sheet metal cladding
Light table measuring surface	Laminate glass, toughened with integral diffusion layer
Light source	High efficiency fluorescent tubes or LEDs with high frequency digital control gear
Mast construction	Heavy folded sheet metal construction
Power supply	230 Volt, single phase, 50Hz or 110 Volt, single phase, 60Hz on request
Power consumption	4 Amp maximum at 230 Volt, 8 Amp max at 110 Volt
Protective devices	Circuit breakers, mounted at rear of light table
Control panel	Control switches for power, camera and lights. Main power indicator
EC directives	Compliant with Machinery, Low voltage and EMC Directives
Paint colour (powder paint)	RAL5013 (cobalt blue)
Ambient operating conditions	10-30 degree C
Approx Footprint/installed width/ depth/ height/ weight of installed Light table and Mast	3360 (W) x 2145mm (D) x 3599mm (H) <1400kgs
Approx Footprint/installed width/ depth/ height/weight of installed Computer Cabinet (inc keyboard tray)	587mm (W) x 900mm (D) x 1675 (H) <100kgs
Standard packing	Export crates suitable for sea shipping (3 nos)
Warranty	One year limited warranty on hardware and software
Optional extended warranty	Two or three year extended warranty (requires software upgrade option)
Software support option	Annual support contract provides free software upgrades

*The first accuracy value specifies the accuracy achieved over most of the table, the second accuracy value specifies the accuracy achieved at table edges

**Accuracy results are verified on standard production machines using tests based on ISO 10360

Actual measuring accuracies achieved will depend on operating environment, user input, quality and condition of materials

Errors and omissions excepted

Due to our policy of continuous improvement specifications are subject to change without notice, please contact factory or your InspecVision dealer



Manufacturer:

InspecVision Ltd

10 Trench Road

Mallusk

Newtownabbey BT36 4TY

Co Antrim United Kingdom

Telephone: +44 (0) 28 90 844 012

Telefax: +44 (0) 870 706 1614

Email: Info@InspecVision.com

Web Address: www.InspecVision.com

Distributor Details:

P360.35L Schematic

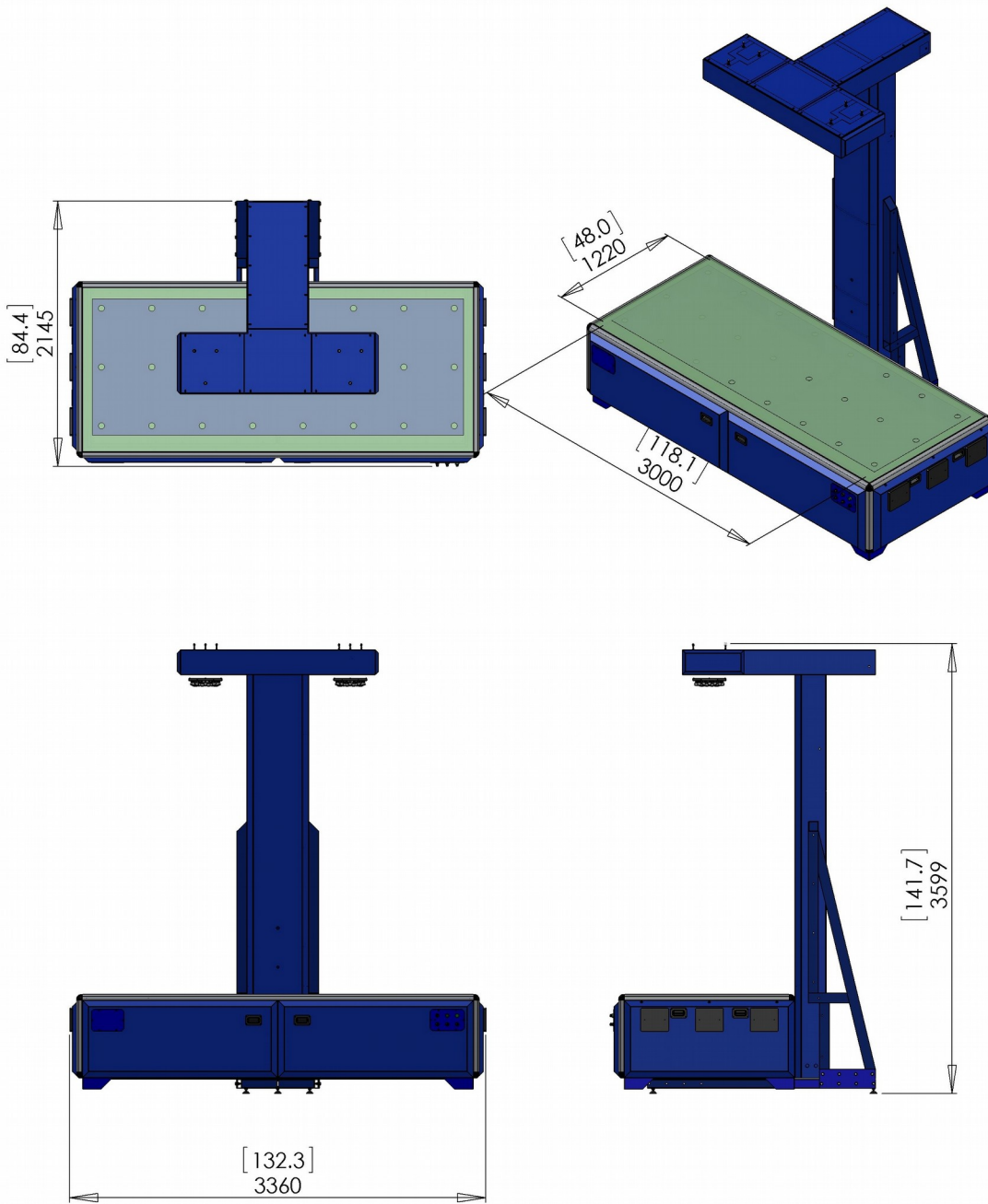

Dimensions in brackets are in inches